

## Armadio ante scorrevoli tetto inclinato

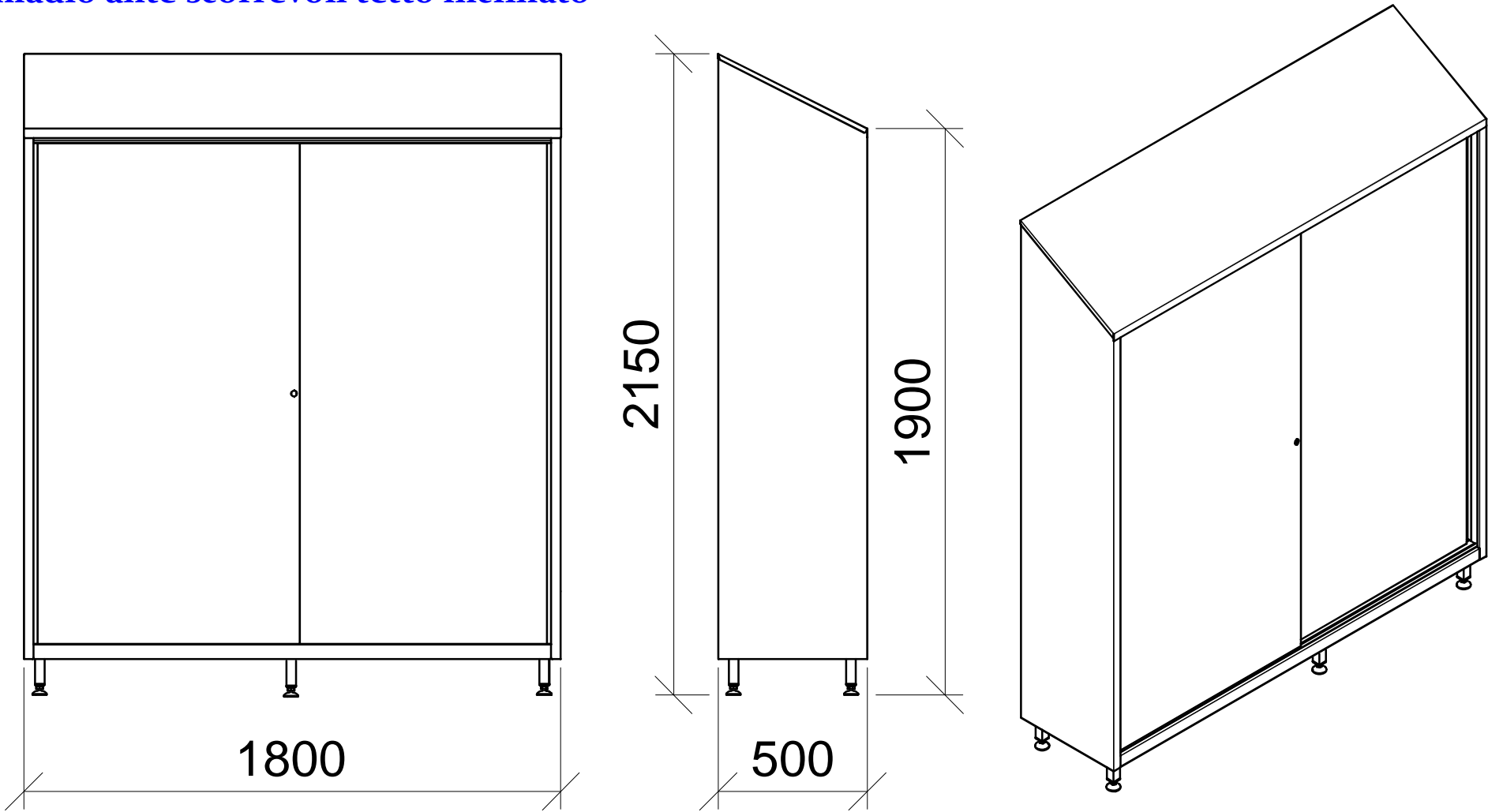

### Caratteristiche:

- in acciaio inox sp. 1.0mm;
- finitura spazzolata 2J (Scotch-Brite®);
- tetto inclinato;
- serratura a chiave;
- 8 ripiani regolabili;
- divisoria verticale;
- ganci in acciaio inox.

Codice: X6022

**FACILITAS**

via Lazio 7 A/B/C - 41050 Montale Rangone (MO)  
Web: [www.facilitas.it](http://www.facilitas.it) @: [facilitas@facilitas.it](mailto:facilitas@facilitas.it)  
Tel: +39-059-530570 Fax: +39-059-4909000